



TIMBER AWNING WINDOW

BUILD IN DETAILS AND CROSS SECTIONS

G:\R&D\PRODUCT DESIGN\05_TIMBER\10 - BUILD IN DETAILS\TREND\10 - BUILD IN DETAILS\TIMBER AWNING.DWG

A	FIRST RELEASE	07/06/2024	DH	CA
ISS.	RELEASE NOTES	DATE	DRAWN	APPRD.

HEAD

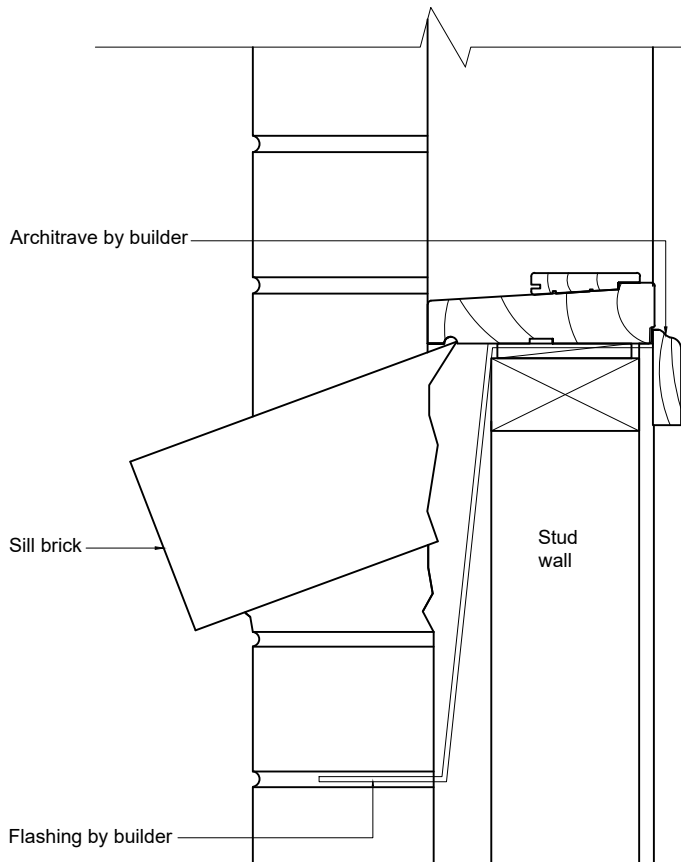
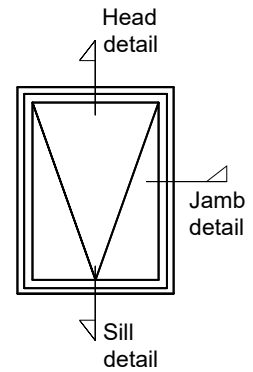
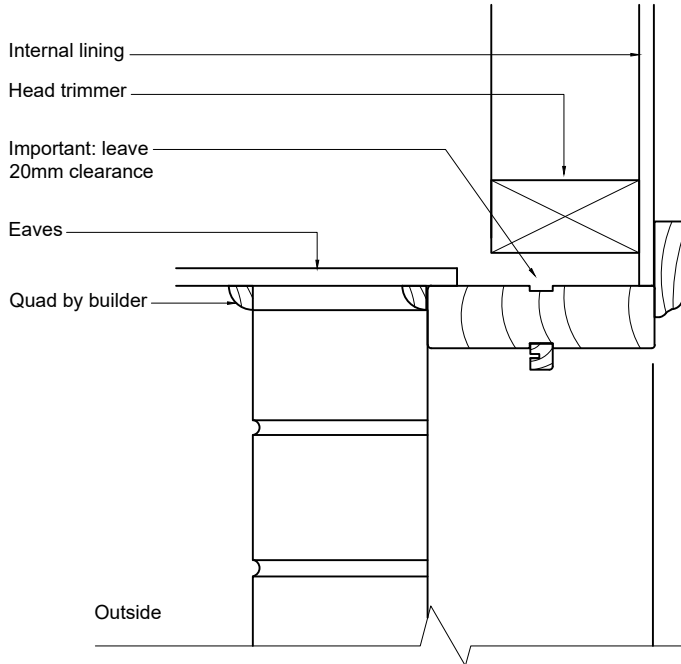

SILL

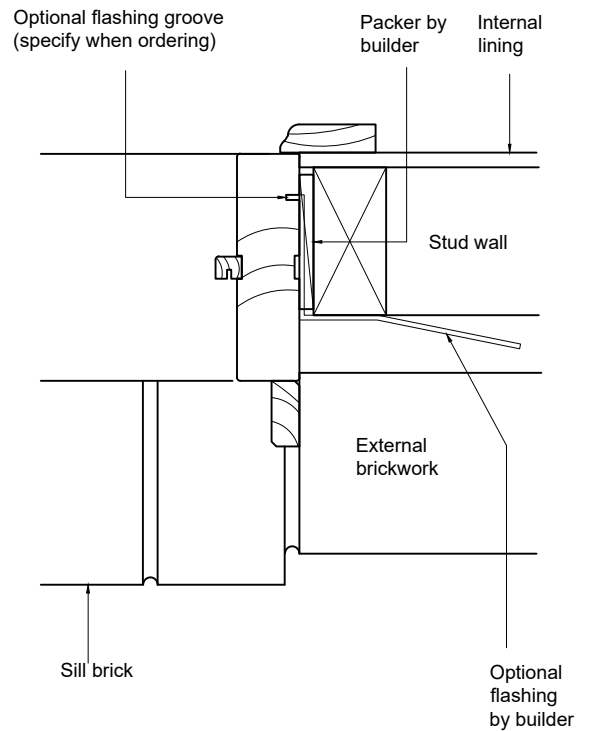

JAMB

The installation and flashing detail shown above is only a suggestion – it is not the only method available and may not be suitable for all applications. It is the responsibility of the builder, installer or purchaser to ensure that the windows are adequately sealed into the building fabric to prevent the ingress of water. We accept no responsibility for damage or consequential loss caused by the failure of the builder, installer or purchaser to provide an adequate flashing system. The wall system manufacturer may have different installation suggestions or requirements. The advice to the builder, installer or purchaser is to seek the wall system manufacturer's requirements for installation and flashing and to seek clarification from the wall system manufacturer if different.

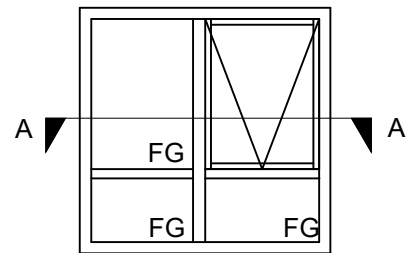
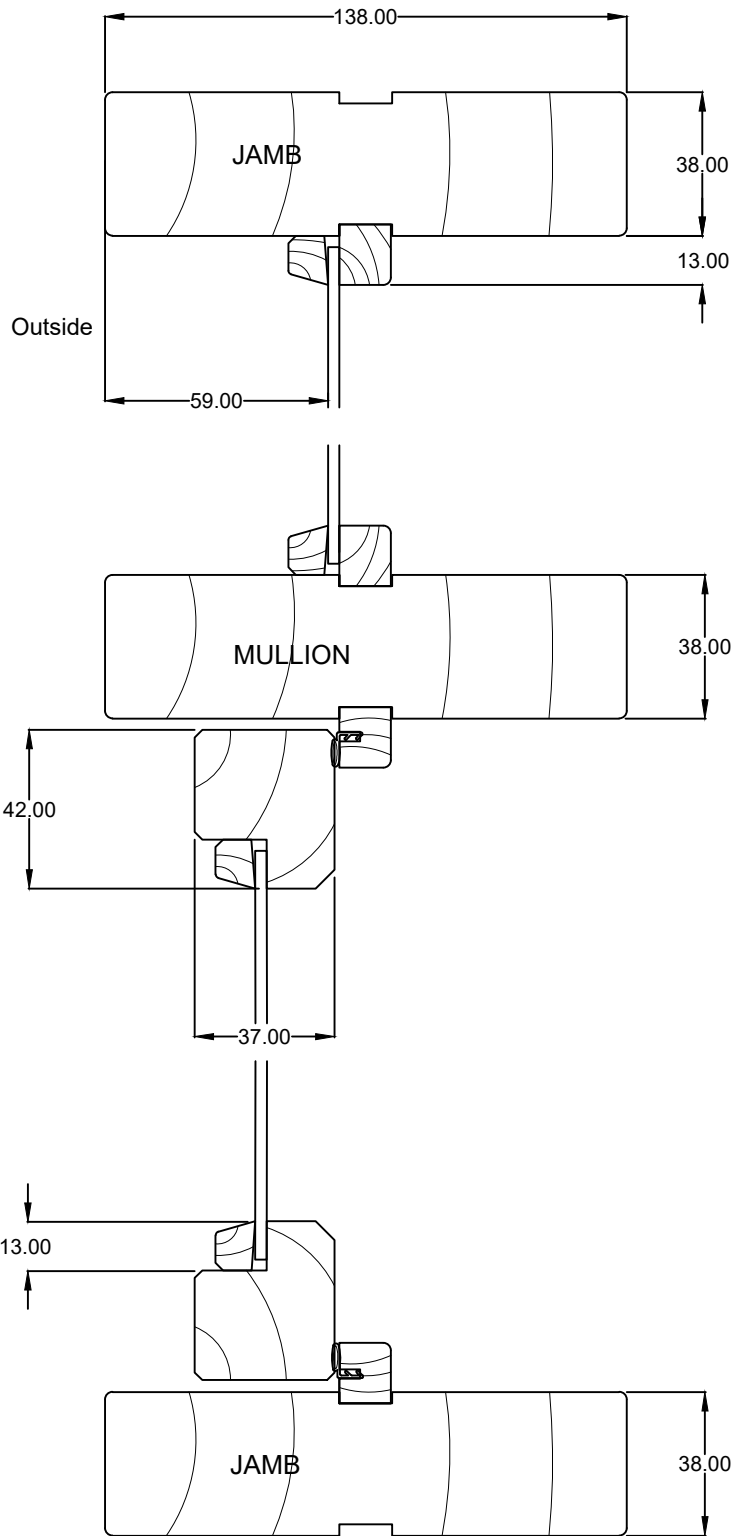

Applicable for Cedar Windows. Sizes may differ for Meranti Windows.

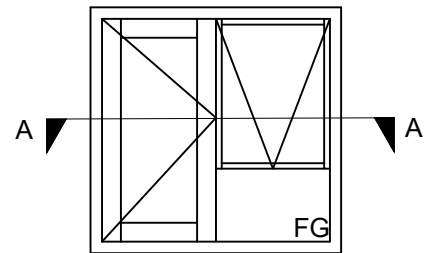
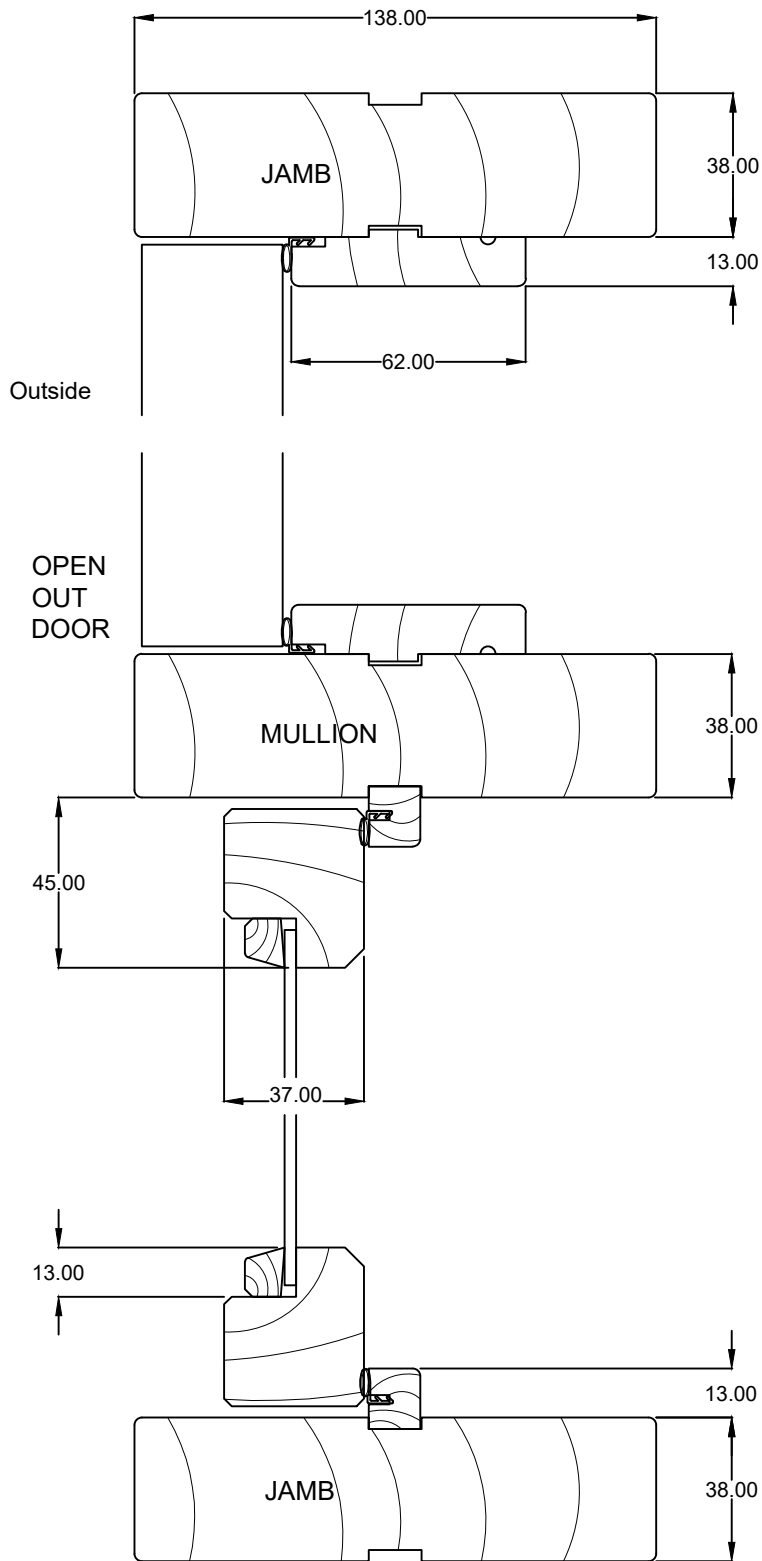

G:\R&D\PRODUCT DESIGN\03_TIMBER\10 - BUILD IN DETAILS\TREND\BID TIMBER AWNING.DWG

Applicable for Cedar Windows. Sizes may differ for Meranti Windows.